

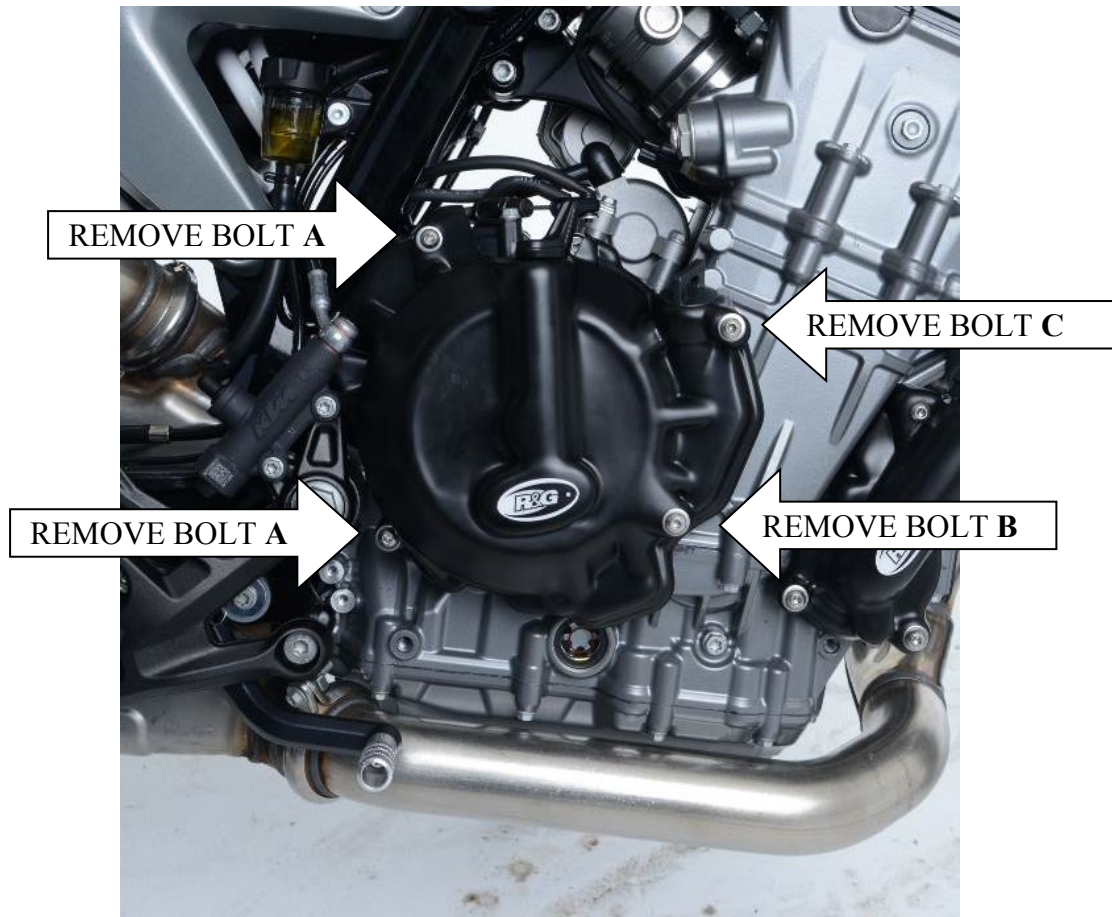

FITTING INSTRUCTIONS FOR ECC0261 KTM DUKE 2018- RHS ENGINE CASE COVER



KIT CONTENTS:

- 1x RHS ENGINE CASE COVER (ECC0261)
- 2 x M6 x 35mm LONG BUTTON HEAD BOLTS (A)
- 1 x M6 x 40mm LONG BUTTON HEAD BOLTS (B)
- 1 x M6 x 45mm LONG BUTTON HEAD BOLTS (C)
- 4 x S0820 SPACERS
- 4 x M6 WASHERS

Digital copies of these instructions are available to download from www.rg-racing.com

GENERAL TORQUE SETTINGS

- M4 BOLT = 8Nm
- M5 BOLT = 12Nm
- M6 BOLT = 15Nm
- M8 BOLT = 20Nm
- M10 BOLT = 40Nm



PLEASE READ THESE INSTRUCTIONS FULLY BEFORE STARTING

- Please make sure the engine is cold before proceeding with the fitting of the R&G cover.
- To fit the R&G engine case cover remove the four M6 engine case bolts in the positions arrowed above using a T30 Torx tool. Hold the cover loosely over the case to help identify the correct ones.
- Fit the four spacers into the four holes of the engine case cover, as shown in the diagram below. Ensure they are correctly seated before proceeding, as this will aid fitting.

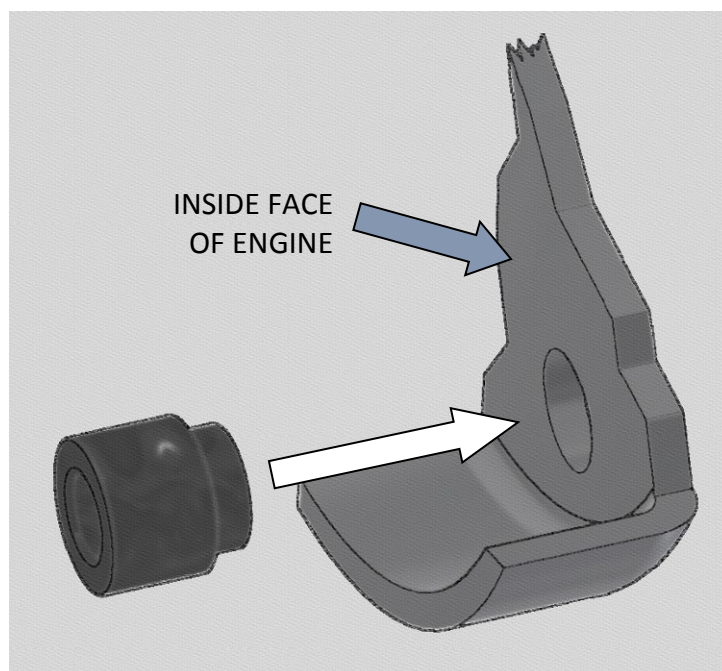

- Offer up the R&G cover to the engine and carefully fit it over the casing.
- Ensure that the R&G bolts spacers are lined up with the holes in the engine casing, and then push on as far as it will go.
- Using a washer, fit the correct length bolts as detailed by the letter in the 'kit contents' list, corresponding to the image on page 1. Fasten through the Engine Case Cover and into the engine case.
- With a 4mm Allen key tighten the bolts equally so that they pull the cover into place. **DO NOT FULLY TIGHTEN.**
- Finally use a torque wrench set at 10 N/m (7 Lb/ft) to fully tighten.
- It is suggested that you check the tightness of the mounting bolts on a regular basis i.e. when cleaning or once a month.
- NOTE; for the cleaning of this product you should only use a soft polishing cloth and a mild general cleaning agent.
- **AVOID HARMFUL CHEMICALS. IF IN DOUBT DO NOT USE AS THEY COULD ALTER THE STRENGTH OF THE COVER.**
- R&G will accept no liability if the above procedure and torque settings are not followed.

ISSUE 1 06/02/2019 (DM)

R&G

Unit 1, Shelley's Lane, East Worldham, Alton, Hampshire, GU34 3AQ
 Tel: +44 (0)1420 89007 Fax: +44 (0)1420 87301 www.rg-racing.com Email: info@rg-racing.com



CONSUMER NOTICE

The catalogue description and any exhibition of samples are only broad indications of the Products and R&G may make design changes which do not diminish their performance or visual appeal and supplying them in such state shall conform to the order. The Buyer acknowledges no representation or warranty (other than as to title) has been given or will apply to the Products other than those in R&G's order or confirmation and the Buyer confirms it has chosen the Products as being of merchantable quality and suitable for its particular purposes. Where R&G fits the Products or undertakes other services it shall exercise reasonable skill and care and rectify any fault free of charge unless the workmanship has been disturbed. The Buyer is responsible for ensuring that the warranty on the motorcycle is not affected by the fitting of the Products. On return of any defective Products R&G shall at its option either supply a replacement or refund the purchase money but shall not be liable if the Products have been modified or used or maintained otherwise than in accordance with R&G's or manufacturer's instructions and good engineering practice or if the defect arises from accident or neglect. Other than identified above and subject to R&G not limiting its liability for causing death and personal injury, it shall not be liable for indirect or consequential loss and otherwise its liability shall be limited to the amounts paid by the Buyer for the Products or the fitting or service concerned. These terms do not affect the Buyer's statutory rights.

R&G RACING RETURNS POLICY (NON-FAULTY GOODS)

Returns must be pre-authorized (if not pre-authorized the return will be rejected). Goods may only be returned direct to us if they were purchased direct from us (customer must prove if necessary). Otherwise to be returned to original vendor. Goods must be in re-sellable condition, in the opinion of R&G Racing. All returns are subject to a 25% restocking and handling fee (25% of the gross value exc. P&P – at the prevailing price at time of purchase). The customer must pay any and all carriage charges. No returns of discontinued products, unless within 14 days of purchase. This policy does not affect your statutory rights and does not refer to faulty goods.

R&G

Unit 1, Shelley's Lane, East Worldham, Alton, Hampshire, GU34 3AQ

Tel: +44 (0)1420 89007 Fax: +44 (0)1420 87301 www.rg-racing.com Email: info@rg-racing.com



**NOTICE DE MONTAGE POUR ECC0261 KTM DUKE 2018-
PROTECTION CARTER MOTEUR DROIT**

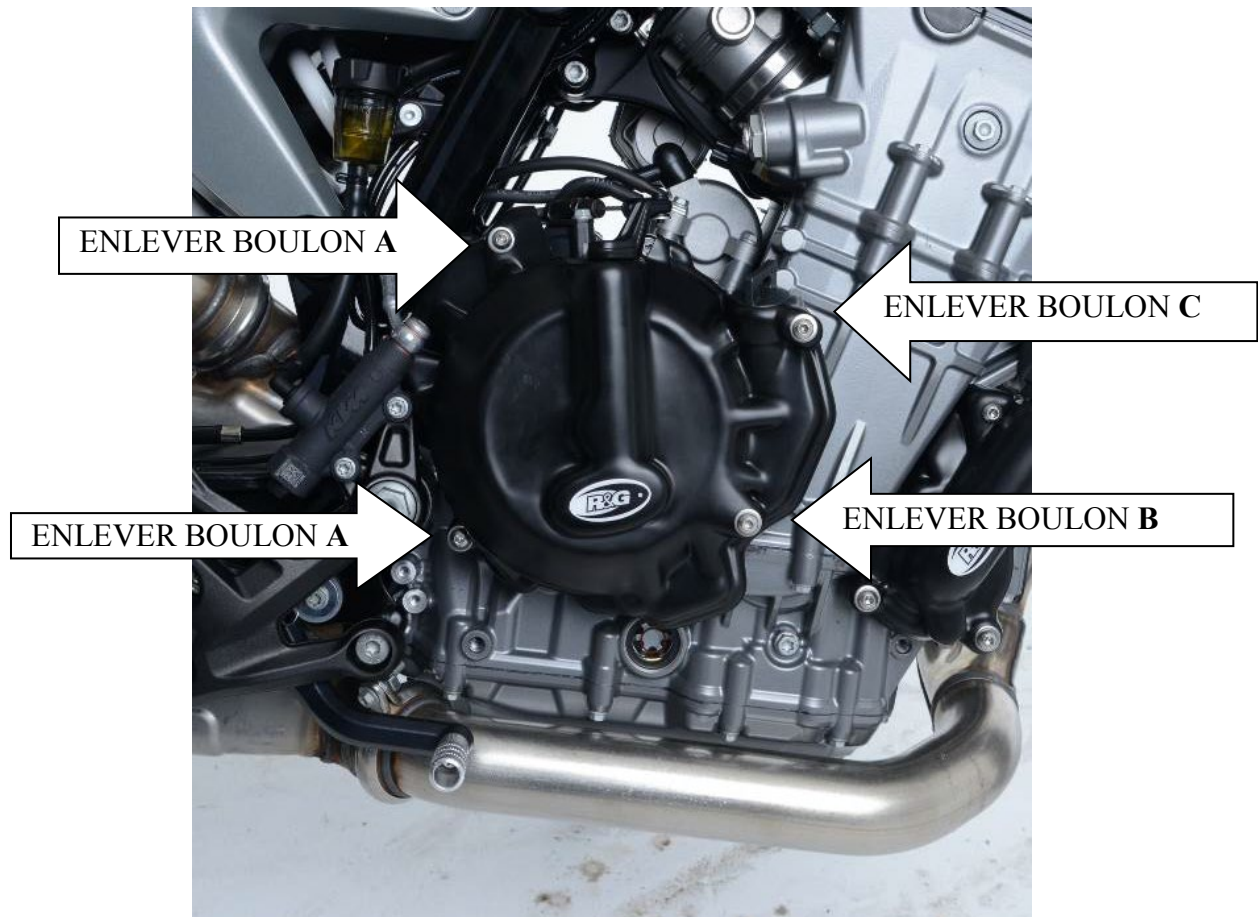

Le kit doit contenir :

- 1x Protection carter moteur côté droit (ECC0261)
- 2 x M6 x 35mm Boulons (A)
- 1 x M6 x 40mm Boulons (B)
- 1 x M6 x 45mm Boulons (C)
- 4 x S0820 Entretoises
- 4 x M6 Rondelles

Notice disponible au téléchargement sur www.rg-racing.com

VALEURS DE SERRAGE

- M4 BOULON = 8Nm
- M5 BOULON = 12Nm
- M6 BOULON = 15Nm
- M8 BOULON = 20Nm
- M10 BOULON = 40Nm



LIRE L'ENSEMBLE DES INSTRUCTIONS AVANT DE COMMENCER

- Assurez-vous que le moteur soit froid.
- Pour monter la protection R&G, enlever les 4 boulons M6 de carter moteur dans les positions indiquées ci-dessus en utilisant une clé Torx T30. Tenir le couvercle autour du carter pour aider à les identifier.
- Insérer les 3 entretoises dans les 3 trous de la protection carter moteur, voir schéma ci-dessous. Veiller à ce qu'elles soient correctement positionnées avant de procéder, cela facilitera le montage.

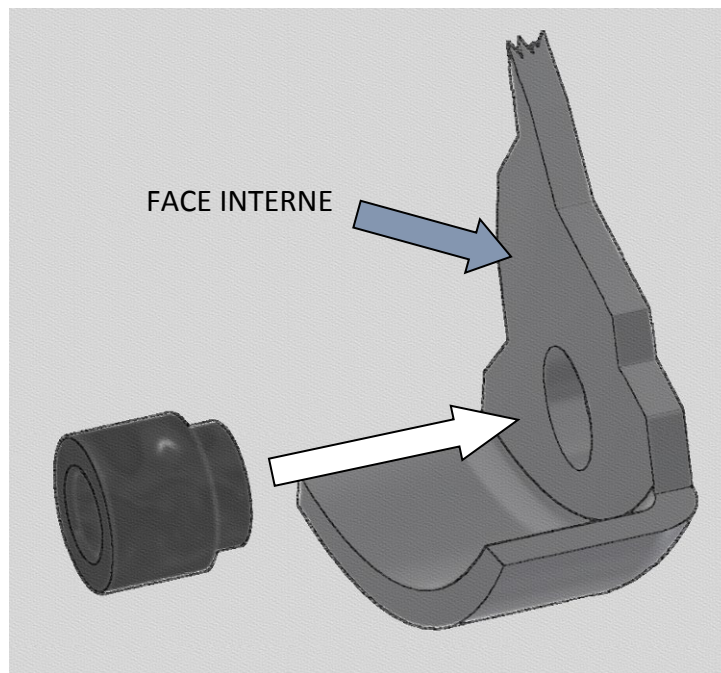

- Monter la protection R&G sur le moteur puis montez la sur le carter.
- Veiller à ce que les boulons R&G soient alignés avec les trous du carter moteur, puis poussez jusqu'à la limite.
- Utiliser une rondelle, insérer les boulons adéquats comme détaillé par la lettre dans la liste de "contenu du kit", correspondant à l'image en page 1. Serrer dans la protection carter moteur puis dans le carter moteur.
- Serrer les boulons de façon identique, avec une clé Allen 4mm de façon à ce que la cache se mette en place. **NE PAS SERRER COMPLETEMENT.**
- Utiliser une clé dynamométrique à 10 Nm (7 Lb ft) pour bloquer.
- Nous vous suggérons de vérifier le serrage au moins une fois par mois, lors du nettoyage par.
- NOTE : Pour le nettoyage, vous devriez utiliser uniquement un chiffon doux et un agent nettoyant doux.
- Ne pas utiliser d'agents chimiques qui pourraient altérer l'efficacité de la protection.
- R&G n'acceptera aucune responsabilité en cas de mauvais couple de serrage ou d'utilisation inappropriée d'agents nocifs.

ISSUE 1 06/02/2019 (DM)



CONSUMER NOTICE

The catalogue description and any exhibition of samples are only broad indications of the Products and R&G may make design changes which do not diminish their performance or visual appeal and supplying them in such state shall conform to the order. The Buyer acknowledges no representation or warranty (other than as to title) has been given or will apply to the Products other than those in R&G's order or confirmation and the Buyer confirms it has chosen the Products as being of merchantable quality and suitable for its particular purposes. Where R&G fits the Products or undertakes other services it shall exercise reasonable skill and care and rectify any fault free of charge unless the workmanship has been disturbed. The Buyer is responsible for ensuring that the warranty on the motorcycle is not affected by the fitting of the Products. On return of any defective Products R&G shall at its option either supply a replacement or refund the purchase money but shall not be liable if the Products have been modified or used or maintained otherwise than in accordance with R&G's or manufacturer's instructions and good engineering practice or if the defect arises from accident or neglect. Other than identified above and subject to R&G not limiting its liability for causing death and personal injury, it shall not be liable for indirect or consequential loss and otherwise its liability shall be limited to the amounts paid by the Buyer for the Products or the fitting or service concerned. These terms do not affect the Buyer's statutory rights.

R&G RACING RETURNS POLICY (NON-FAULTY GOODS)

Returns must be pre-authorized (if not pre-authorized the return will be rejected). Goods may only be returned direct to us if they were purchased direct from us (customer must prove if necessary). Otherwise to be returned to original vendor. Goods must be in re-sellable condition, in the opinion of R&G Racing. All returns are subject to a 25% restocking and handling fee (25% of the gross value exc. P&P – at the prevailing price at time of purchase). The customer must pay any and all carriage charges. No returns of discontinued products, unless within 14 days of purchase. This policy does not affect your statutory rights and does not refer to faulty goods.

R&G

Unit 1, Shelley's Lane, East Worldham, Alton, Hampshire, GU34 3AQ

Tel: +44 (0)1420 89007 Fax: +44 (0)1420 87301 www.rg-racing.com Email: info@rg-racing.com



**MONTAGEANLEITUNG FÜR ECC0261 KTM DUKE 2018-
MOTORGEHÄUSE-ABDECKUNG – RECHTE SEITE**

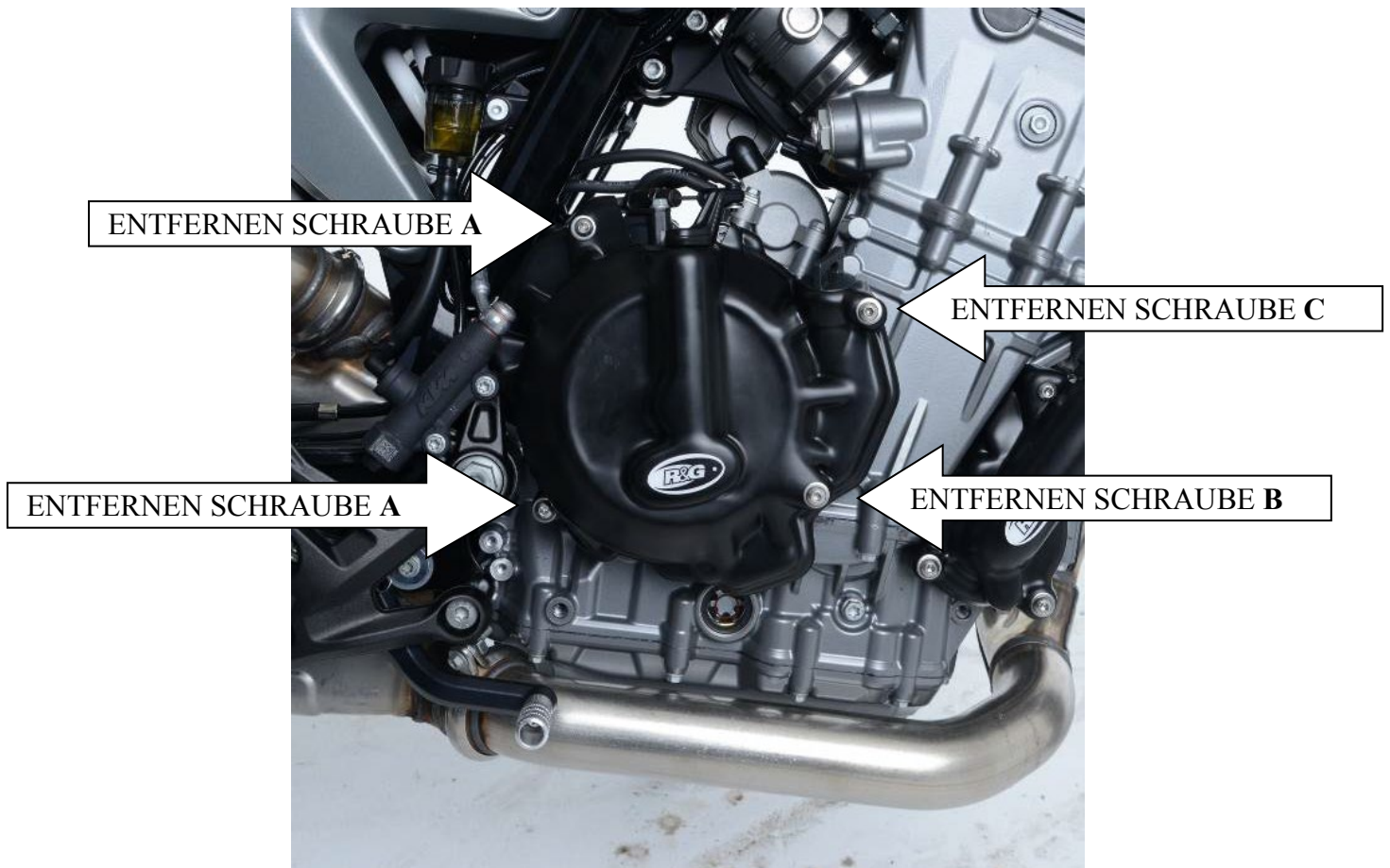

INHALT DES KITS:

- 1x ABDECKUNG MOTORGEHÄUSE RECHTE SEITE (ECC0261)
- 2 x M6 x 35mm INBUSSCHRAUBE (A)
- 1 x M6 x 40mm INBUSSCHRAUBE (B)
- 1 x M6 x 45mm INBUSSCHRAUBE (C)
- 4 x S0820 DISTANZHALTER
- 4 x M6 UNTERLEGSCHIEBEN

Eine digitale Version dieser Montageanleitung kann auf folgender Seite heruntergeladen werden: www.rg-racing.com

ALLGEMEINE ANZUGSDREHMOMENTE

- M4 SCHRAUBE = 8Nm
- M5 SCHRAUBE = 12Nm
- M6 SCHRAUBE = 15Nm
- M8 SCHRAUBE = 20Nm
- M10 SCHRAUBE = 40Nm

R&G



BITTE LESEN SIE DIE MONTAGEANLEITUNG DURCH, BEVOR SIE MIT DER MONTAGE BEGINNEN.

- Bitte achten Sie unbedingt darauf, dass der Motor kalt ist, bevor Sie mit der Montage der R&G Abdeckung beginnen.
- Um die R&G Motorgehäuse-Abdeckung montieren zu können, entfernen Sie die vier M6 Motorgehäuse-Schrauben, die oben gekennzeichnet sind, mit einem T30 Torx-Schlüssel. Um die richtigen Schrauben identifizieren zu können, halten Sie die Abdeckung an das Gehäuse.
- Montieren Sie die vier Distanzhalter an den vier Öffnungen in der Motorgehäuse-Abdeckung wie unten abgebildet. Bitte stellen Sie sicher, dass sie richtig positioniert sind, bevor Sie fortfahren.

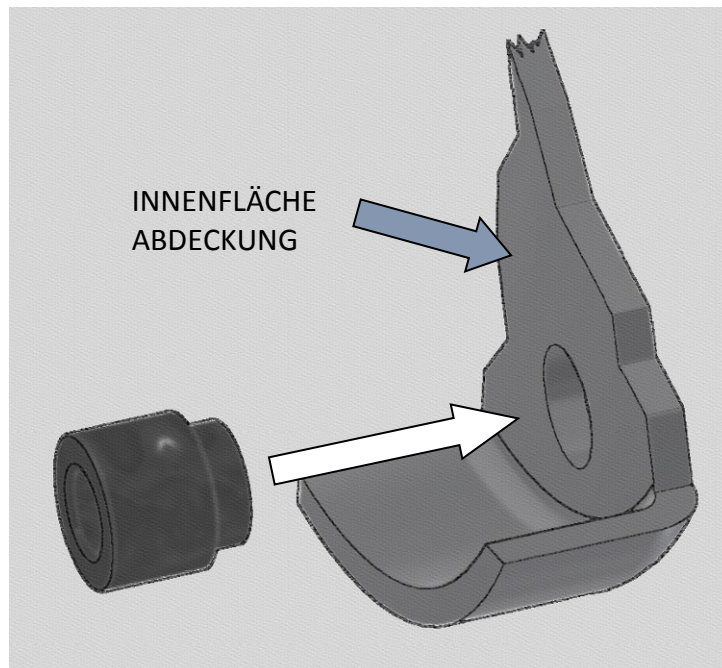

- Die R&G Abdeckung an den Motor ansetzen und vorsichtig am Gehäuse anbringen.
- Stellen Sie sicher, dass die R&G Schrauben Distanzhalter mit den Bohrungen im Motorgehäuse ausgerichtet sind, und die Abdeckung soweit wie möglich eindrücken.
- Montieren Sie die Schrauben mit der jeweils passenden Länge und einer Unterlegscheibe (die Schrauben sind zusätzlich mit Buchstaben gekennzeichnet in der Aufstellung „Inhalt des Kits“) an der entsprechenden Position wie in der Abbildung auf Seite 1 abgebildet. Die Schrauben hierbei durch die Motorgehäuse-Abdeckung ins Motorgehäuse einführen.
- Ziehen Sie die Schrauben mit einem 4mm Inbusschlüssel gleichmäßig an, sodass sie die Abdeckung in Position ziehen. NICHT FESTZIEHEN.
- Anschließend benutzen Sie einen Drehmomentschlüssel, der auf 10 N/m (7 Lb/ft) eingestellt ist, um die Schrauben festzuziehen.
- Es wird empfohlen, die Festigkeit der Montageschrauben in regelmäßigen Abständen zu kontrollieren (d.h. einmal im Monat).

R&G

Unit 1, Shelley's Lane, East Worldham, Alton, Hampshire, GU34 3AQ

Tel: +44 (0)1420 89007 Fax: +44 (0)1420 87301 www.rg-racing.com Email: info@rg-racing.com



- HINWEIS: Bei der Reinigung dieses Produkts benutzen Sie nur ein weiches Poliertuch und ein mildes Putzmittel.
- VERMEIDEN SIE SCHÄDLICHE CHEMIKALIEN. IM ZWEIFELSFALL NICHT BENUTZEN, DA SIE DIE FESTIGKEIT DER ABDECKUNG VERÄNDERN KÖNNEN.
- R&G übernimmt keine Haftung, wenn die obengenannten Schritte nicht eingehalten werden und/oder die angegebenen Anzugsdrehmomente nicht angewendet werden.

AUSGABE 1 06/02/2019 (DM)

CONSUMER NOTICE

The catalogue description and any exhibition of samples are only broad indications of the Products and R&G may make design changes which do not diminish their performance or visual appeal and supplying them in such state shall conform to the order. The Buyer acknowledges no representation or warranty (other than as to title) has been given or will apply to the Products other than those in R&G's order or confirmation and the Buyer confirms it has chosen the Products as being of merchantable quality and suitable for its particular purposes. Where R&G fits the Products or undertakes other services it shall exercise reasonable skill and care and rectify any fault free of charge unless the workmanship has been disturbed. The Buyer is responsible for ensuring that the warranty on the motorcycle is not affected by the fitting of the Products. On return of any defective Products R&G shall at its option either supply a replacement or refund the purchase money but shall not be liable if the Products have been modified or used or maintained otherwise than in accordance with R&G's or manufacturer's instructions and good engineering practice or if the defect arises from accident or neglect. Other than identified above and subject to R&G not limiting its liability for causing death and personal injury, it shall not be liable for indirect or consequential loss and otherwise its liability shall be limited to the amounts paid by the Buyer for the Products or the fitting or service concerned. These terms do not affect the Buyer's statutory rights.

R&G RACING RETURNS POLICY (NON-FAULTY GOODS)

Returns must be pre-authorized (if not pre-authorized the return will be rejected). Goods may only be returned direct to us if they were purchased direct from us (customer must prove if necessary). Otherwise to be returned to original vendor. Goods must be in re-sellable condition, in the opinion of R&G Racing. All returns are subject to a 25% restocking and handling fee (25% of the gross value exc. P&P – at the prevailing price at time of purchase). The customer must pay any and all carriage charges. No returns of discontinued products, unless within 14 days of purchase. This policy does not affect your statutory rights and does not refer to faulty goods.

R&G

Unit 1, Shelley's Lane, East Worldham, Alton, Hampshire, GU34 3AQ

Tel: +44 (0)1420 89007 Fax: +44 (0)1420 87301 www.rg-racing.com Email: info@rg-racing.com